

40 kHz Ultrasonic Receiver & PreAmplifier Board

- Wide Horizontal Beam Directivity
- Broad bandwidth
- Low Q Resonance
- Excellent Impact Resistance
- Low Cost
- Lightweight

Piezoelectric Film (PVDF) Ultrasound Receivers offer unique advantages for air ranging applications. Cylindrical 40kHz PVDF receivers exhibit very wide horizontal beam directivity and broad bandwidth characteristics. These characteristics lend unique solutions in many applications such as two-dimensional positioning, digitizer, object detection, and distance measurement. Depending on the applications, resonance frequency and vertical beam directivity of the receiver can easily be customized by changing the diameter and length of the PVDF cylinder.

The receiver has a very wide horizontal beam angle and it can be reduced by changing the housing design if necessary. PVDF receivers also have very low resonance Q value. Typically, PVDF receivers have a Q value of 4. This means that the rising time and the signal decay time are much faster than the conventional ceramic receivers. This characteristic is suitable for high speed data acquisition or high speed digitizer applications. Also, a preamplifier is available for easy evaluation of 40 kHz receivers.



FEATURES

- PVDF Thickness: 30 μ m
- Resonance Frequency: 40 kHz
- Bandwidth: 10 kHz
- Resonance Q: 4
- Sensitivity Output: 1.5 mV/Pa -76 dB
- Horizontal Beam Directivity: $\pm 150^\circ$
- Vertical Beam Directivity: $\pm 40^\circ$
- Capacitance: 140 pF
- Storage Temperature: -20°C - +85°C
- Operating Temperature: +5°C - +60°C

APPLICATIONS

- Two-dimensional Position Detection
- Digitizer
- Distance Measurement
- Object Detection
- General Purpose Air Ranging Applications

specifications

	Min	Typ	Max	Unit
Supply Voltage		5		VDC
Supply Current		0.03		ADC
Frequency		40		kHz
Gain		31		dB

dimensions

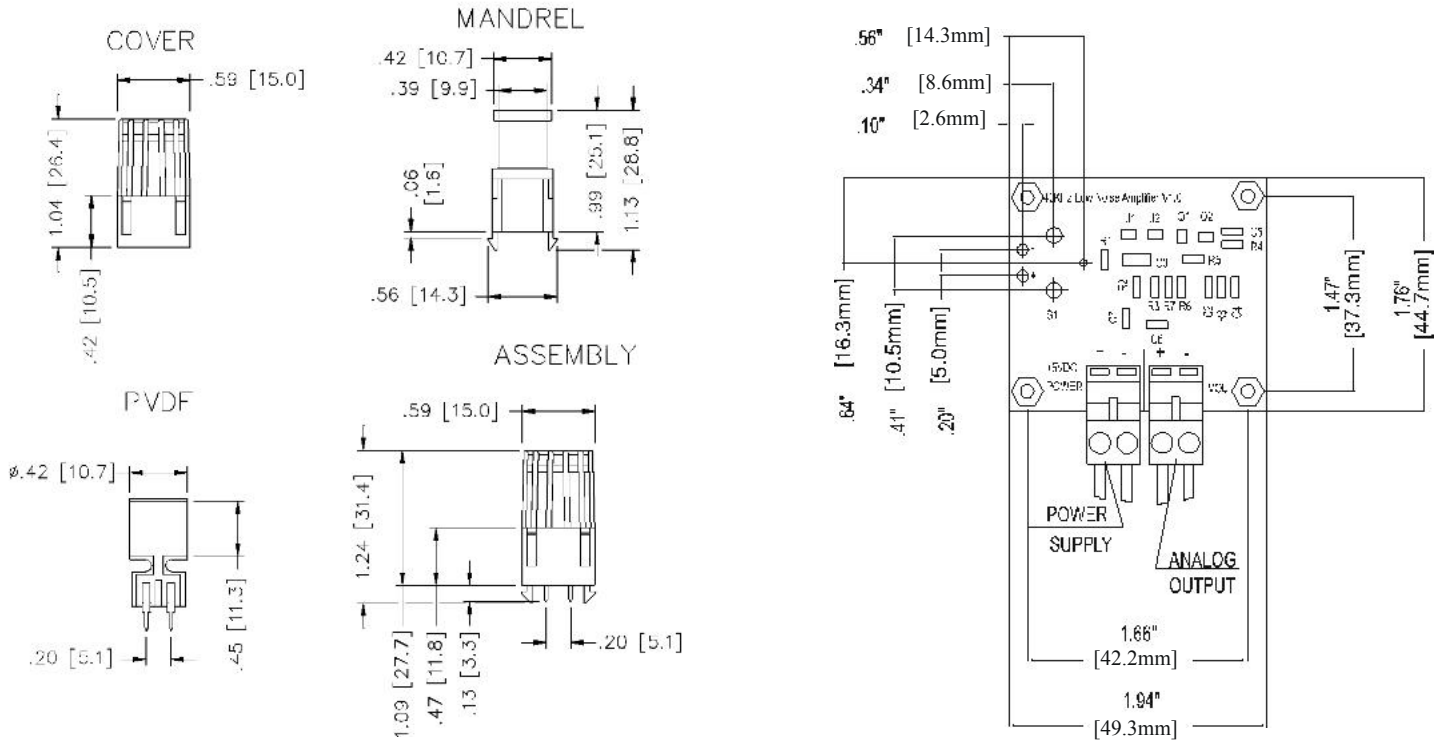
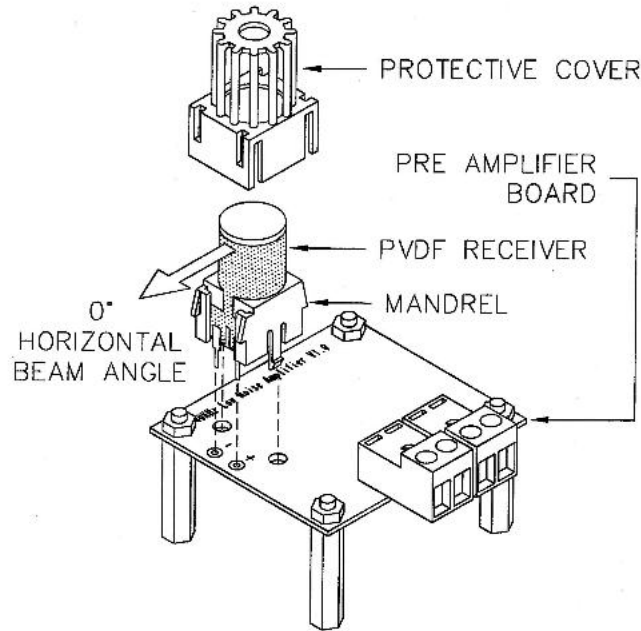

TYPICAL FREQUENCY RESPONSE

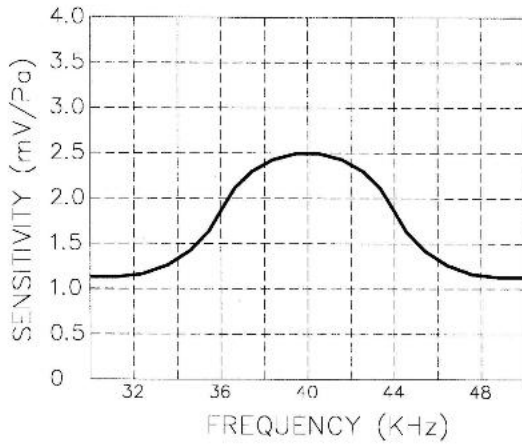

TYPICAL TIME RESPONSE

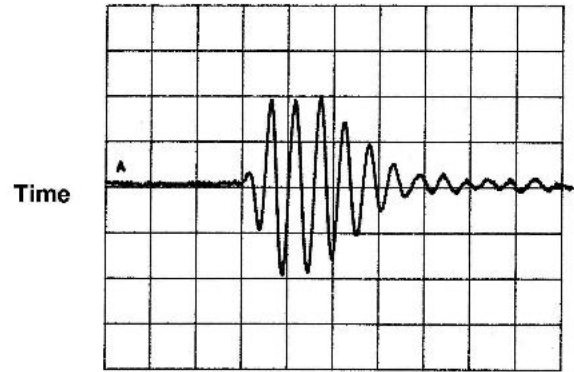

20mV/div, 50 μ s/div

NOTE: Measured with PVDF transmitter (100Vp drive) and preamplifier (gain of 17)

TYPICAL HORIZONTAL BEAM DIRECTIVITY

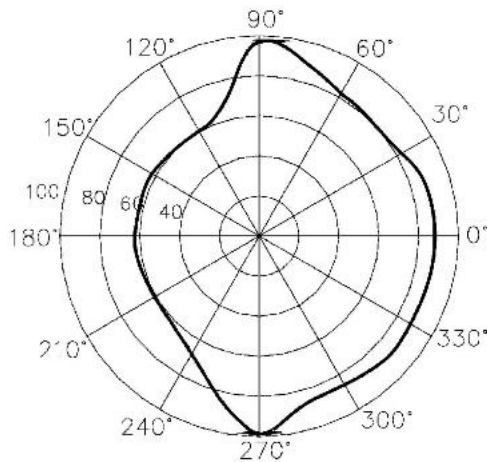

TYPICAL VERTICAL BEAM DIRECTIVITY

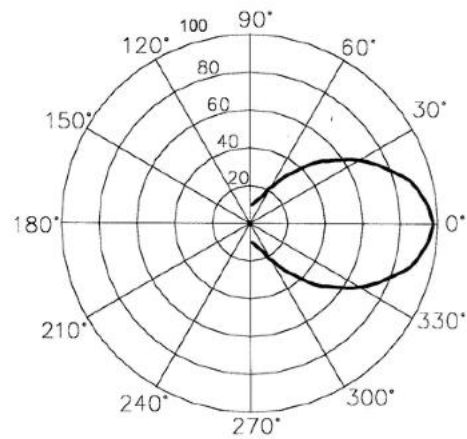

preamplifier gain

Pre-amplifier has gain of 31 and a bandwidth filter to maximize the S/N ratio. The receiver can be snapped onto the pre-amplifier.

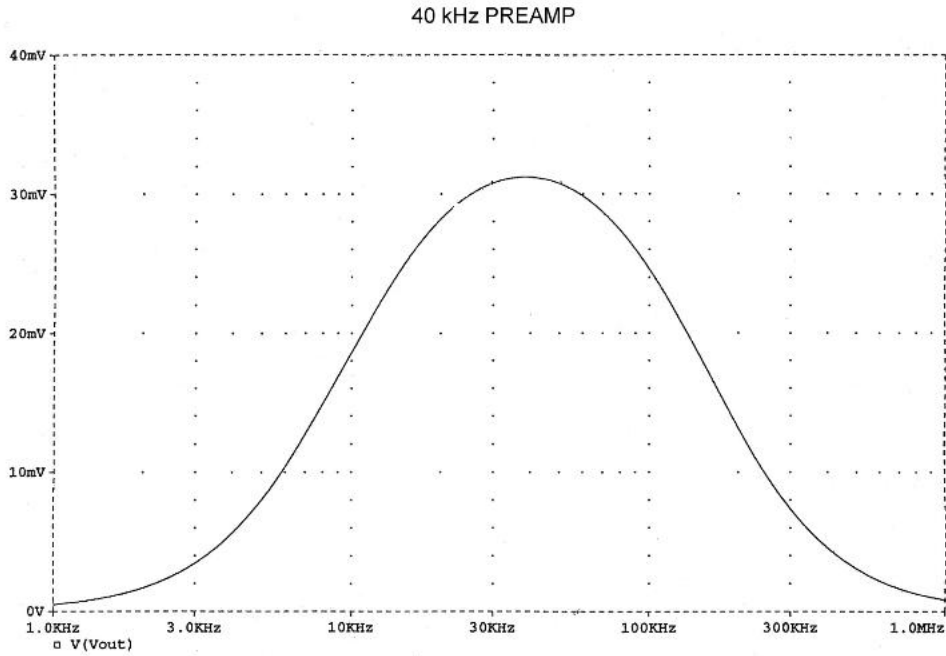

circuit diagram

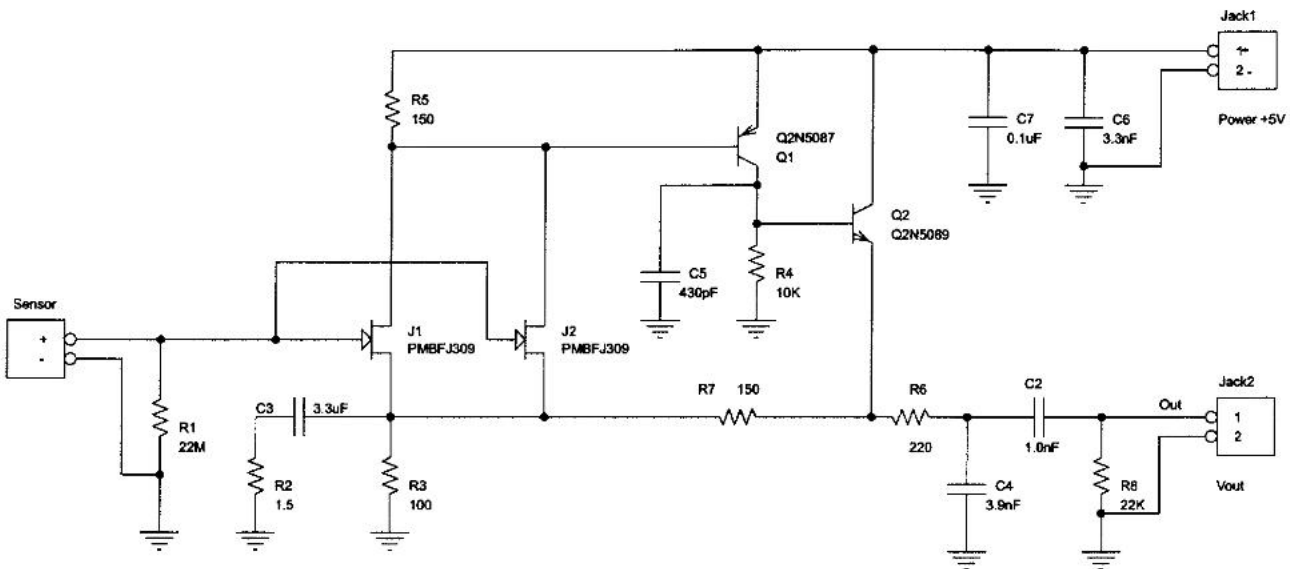

The information in this sheet has been carefully reviewed and is believed to be accurate; however, no responsibility is assumed for inaccuracies. Furthermore, this information does not convey to the purchaser of such devices any license under the patent rights to the manufacturer. Measurement Specialties, Inc. reserves the right to make changes without further notice to any product herein. Measurement Specialties, Inc. makes no warranty, representation or guarantee regarding the suitability of its product for any particular purpose, nor does Measurement Specialties, Inc. assume any liability arising out of the application or use of any product or circuit and specifically disclaims any and all liability, including without limitation consequential or incidental damages. Typical parameters can and do vary in different applications. All operating parameters must be validated for each customer application by customer's technical experts. Measurement Specialties, Inc. does not convey any license under its patent rights nor the rights of others.

ordering information

Description	Part #	Model #
40kHz Receiver	1005856-1	US40KR-01
Preamplifier Board	1005857-1	US40KA-01

Asia

联系方式

智美康科技（深圳）有限公司

ZHIMK TECHNOLOGY (SHEN ZHEN) CO.,LTD.
Shenzhen , China 518033

Tel: +86 755 8303 5030/8989 4565 , 13048972929

Email: liulijun18@126.com

www.zhimk.com.cn